

## G501 Heavy Duty Full Extension Slide

Max load 272 kg

### Features

- Full extension, 3 members slide
- Suitable for heavy duty application

### Recommended Screws

- M4 binding or M4 truss screw

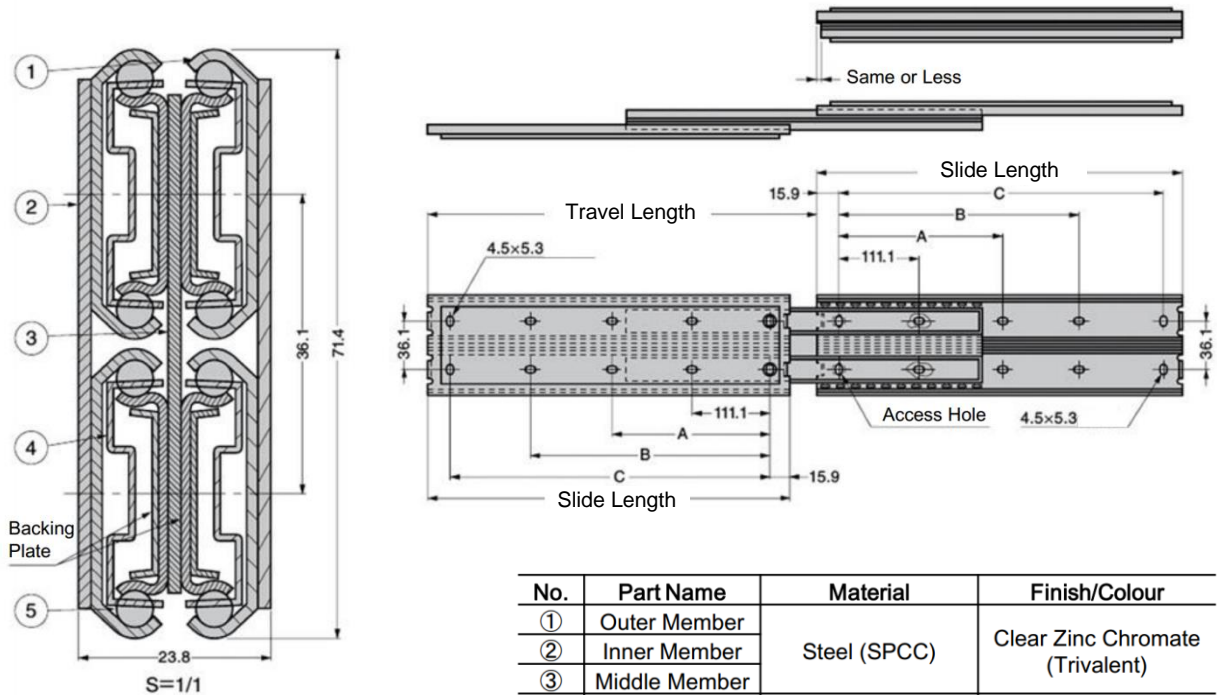

No.	Part Name	Material	Finish/Colour
①	Outer Member	Steel (SPCC)	Clear Zinc Chromate (Trivalent)
②	Inner Member		
③	Middle Member		
④	Retainer	Steel (SECC)	(Zinc Plating)
⑤	Steel Balls	Steel (SWCH)	-

Sold by piece

Part No.	Slide Length	Travel Length	A	B	C	Load Capacity (per pair)	
G501-12	304.8	327	-	149.2	273	2,667 N	272 kg
G501-14	355.6	377.8		200	323.8	2,628 N	268 kg
G501-16	406.4	428.6		250.8	374.6	2,540 N	259 kg
G501-18	457.2	479.4	212.7	301.6	425.4	2,452 N	250 kg
G501-20	508	530.2	238.1	352.4	476.2	2,363 N	241 kg
G501-22	558.8	581	263.5	403.2	527	2,246 N	229 kg
G501-24	609.6	631.8	288.9	454	577.8	2,118 N	216 kg
G501-26	660.4	682.6	314.3	504.8	628.6	1,961 N	200 kg
G501-28	711.2	733.4	339.7	555.6	679.4	1,785 N	182 kg